



DPP to Control LED Brightness

Prepared by: Fabien Franc
ON Semiconductor

Light-emitting diodes (LEDs) require a regulated current, and their brightness is proportional to the current that flows through them. Some LED drivers use an external resistor to set the LED current. A digitally programmable potentiometer (DPP™) can replace a discrete resistor with the advantage of providing an adjustable value allowing the LED brightness to dynamically change. Most DPP circuits have the ability to store permanently the resistor value in non-volatile memory.

This application brief shows a DPP circuit used in combination with the CAT32 white LED driver. The

digitally programmable potentiometer is connected as a 2-terminal variable resistor, as shown in Figure 1. The potentiometer Wiper-to-Low resistor (between W and L pins) is connected in series with the R_{SET} resistor to adjust the LED brightness. This example uses a 32-tap linear potentiometer, the CAT5114, with an end-to-end resistance of 50 kΩ. The wiper terminal (W) position is controlled through a 3-wire interface. The INC input increments the wiper in the direction which is determined by the logic state of the Up/Down input. The CS input is used to select the device and also store the wiper position prior to power down.

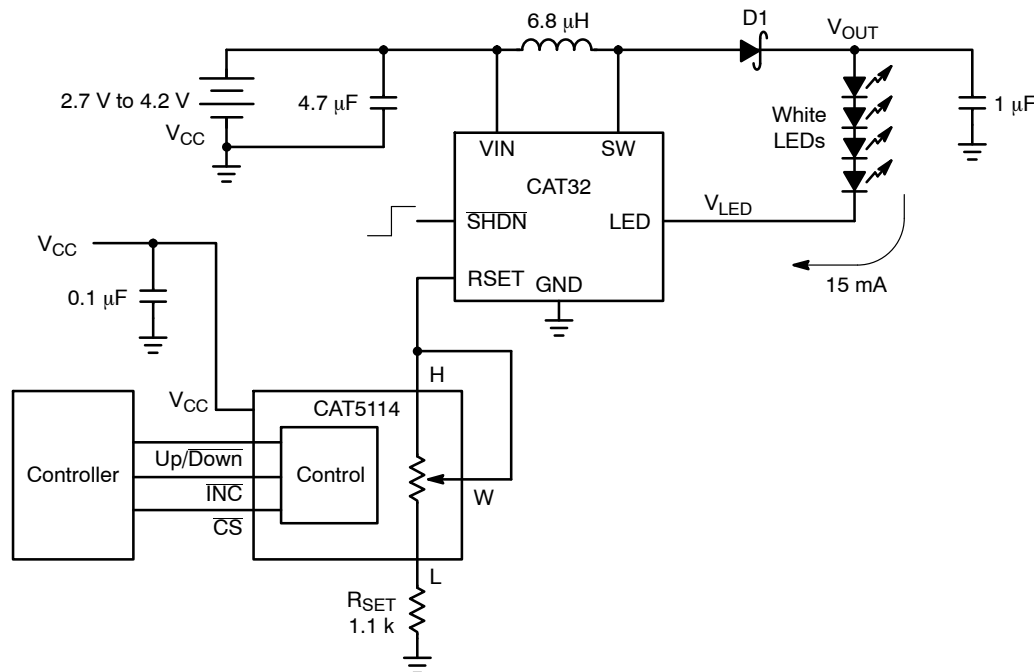

Figure 1. CAT32 LED Driver with CAT5114 Potentiometer Circuit Diagram

AND8412/D

LED Current

The LED current is a function of the total resistance connected to the R_{SET} pin, and is calculated as follows:

$$I_{LED} = \frac{22.5}{R_{SET} + R_{W-L}}$$

R_{SET} defines the minimum resistance and therefore the maximum LED current, for example with R_{SET} = 1.13 kΩ, the LED current is 20 mA. The lowest LED current is

obtained with the largest R_{W-L} of 50 kΩ, which results in an LED current of about 1 mA.

The number of taps define the resolution of the potentiometer or the minimum increment in the resistance. A larger number of taps gives more resolution. Table 1 lists a selection of ON Semiconductor DPPs with their characteristics.

Table 1. DPP SELECTION

Part Number	Number of Taps	Resistor Options (kΩ)	Digital Interface	Resistor Scale	Wiper Memory
CAT5114	32	10, 50, 100	Increment	Linear	1 position
CAT5113	100	10, 50, 100	Increment	Linear	1 position
CAT5116	100	32	Increment	Log	1 position
CAT5115	32	10, 50, 100	Increment	Linear	Volatile

In applications where the LEDs backlight an LCD, such as in cellular phones or PDAs, the LEDs are either turned ON or OFF. The potentiometer can be used to generate a soft fading between those two states.

Information on the DPP products and the LED drivers are available on the ON Semiconductor web site at <http://www.onsemi.com>.

ON Semiconductor and  are registered trademarks of Semiconductor Components Industries, LLC (SCILLC). SCILLC reserves the right to make changes without further notice to any products herein. SCILLC makes no warranty, representation or guarantee regarding the suitability of its products for any particular purpose, nor does SCILLC assume any liability arising out of the application or use of any product or circuit, and specifically disclaims any and all liability, including without limitation special, consequential or incidental damages. "Typical" parameters which may be provided in SCILLC data sheets and/or specifications can and do vary in different applications and actual performance may vary over time. All operating parameters, including "Typicals" must be validated for each customer application by customer's technical experts. SCILLC does not convey any license under its patent rights nor the rights of others. SCILLC products are not designed, intended, or authorized for use as components in systems intended for surgical implant into the body, or other applications intended to support or sustain life, or for any other application in which the failure of the SCILLC product could create a situation where personal injury or death may occur. Should Buyer purchase or use SCILLC products for any such unintended or unauthorized application, Buyer shall indemnify and hold SCILLC and its officers, employees, subsidiaries, affiliates, and distributors harmless against all claims, costs, damages, and expenses, and reasonable attorney fees arising out of, directly or indirectly, any claim of personal injury or death associated with such unintended or unauthorized use, even if such claim alleges that SCILLC was negligent regarding the design or manufacture of the part. SCILLC is an Equal Opportunity/Affirmative Action Employer. This literature is subject to all applicable copyright laws and is not for resale in any manner.

PUBLICATION ORDERING INFORMATION

LITERATURE FULFILLMENT:

Literature Distribution Center for ON Semiconductor
P.O. Box 5163, Denver, Colorado 80217 USA
Phone: 303-675-2175 or 800-344-3860 Toll Free USA/Canada
Fax: 303-675-2176 or 800-344-3867 Toll Free USA/Canada
Email: orderlit@onsemi.com

N. American Technical Support: 800-282-9855 Toll Free
USA/Canada
Europe, Middle East and Africa Technical Support:
Phone: 421 33 790 2910
Japan Customer Focus Center
Phone: 81-3-5773-3850

ON Semiconductor Website: www.onsemi.com

Order Literature: <http://www.onsemi.com/orderlit>

For additional information, please contact your local Sales Representative